

Pre Quiz

- 1) **What do all waves transport from one place to another?**

- 2) **In which of the following scenarios would the Doppler effect be present?**
 - a) **A police car, with its siren sounding, speeds past you as you sit in your car at a stop light.**
 - b) **A firefighter turns on the siren in a parked fire truck as a demonstration for the crowd of young children.**
 - c) **The coach blows his whistle in the gym during basketball practice.**
 - d) **You shout to a friend while inside a cave.**

Pre Quiz



- 3) **True or False:** As light travels from one medium into another, such as from air to water, it will refract.
- 4) Which wave property is demonstrated when you look into a mirror and see yourself?

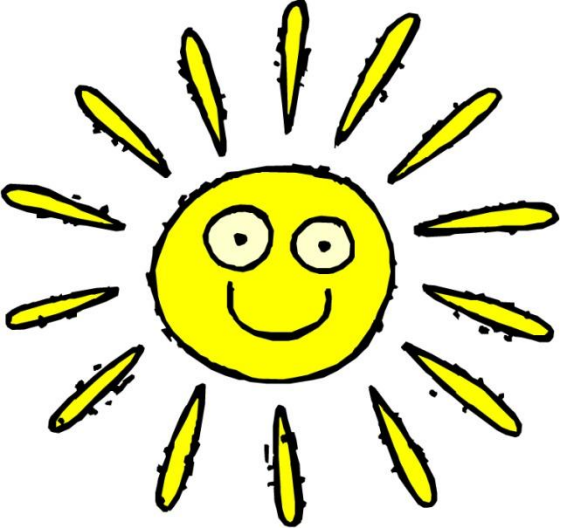

Ch 24.1: The Study of Light

Describe the waves that compose the electromagnetic spectrum.

Describe what the different types of spectra reveal about stars.



Electromagnetic Radiation

- The vast majority of our information about the universe is obtained from the study of light.
- Light is only a small part of the different types of energy known as electromagnetic radiation.
 - It includes gamma rays, X-rays, UV, visible light, IR, microwaves, and radio waves.
 - All energy travels through space at the speed of light
(186,000 miles a second)

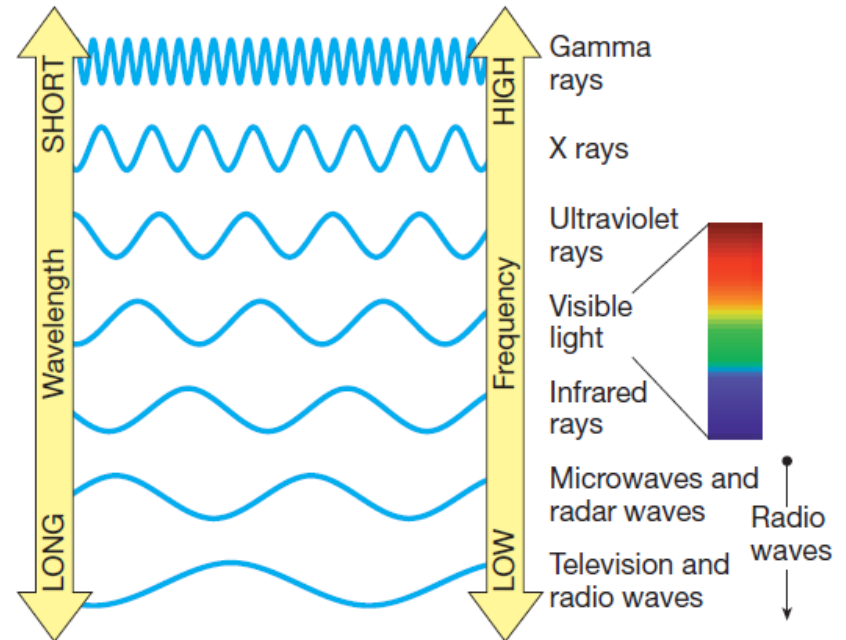
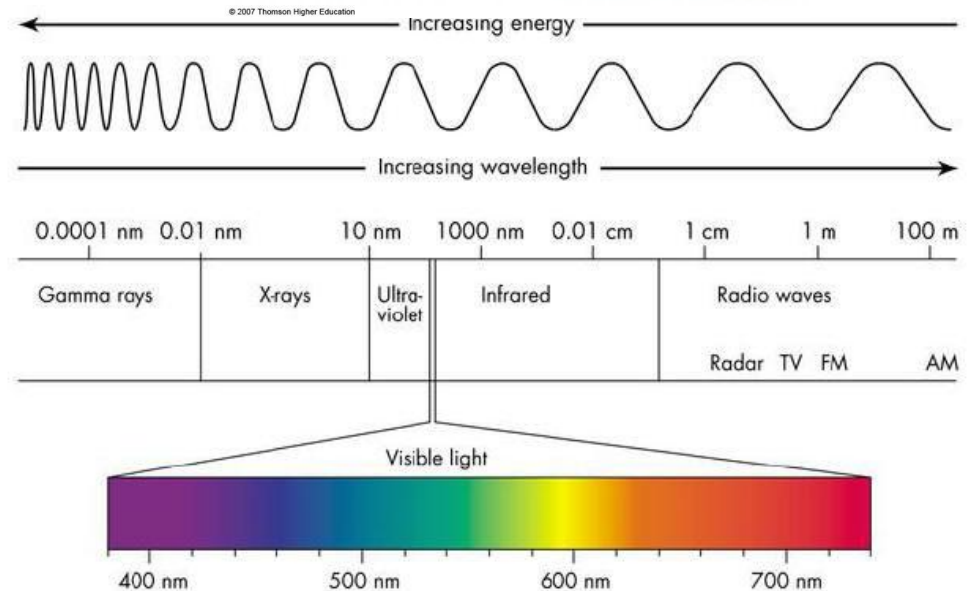
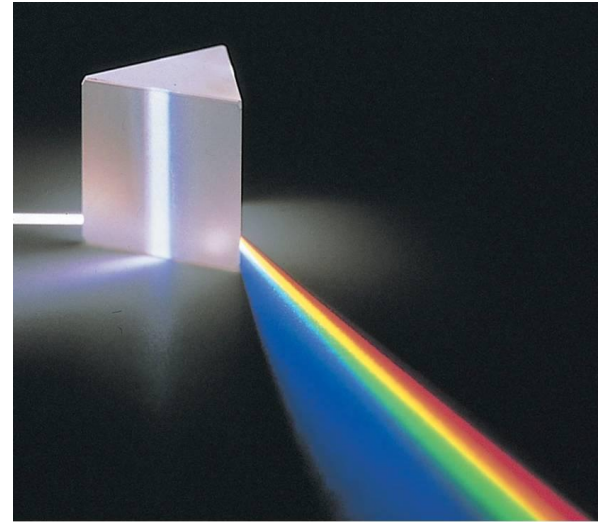

Figure 1 Electromagnetic Spectrum The electromagnetic spectrum classifies radiation according to wavelength and frequency.

Interpreting Diagrams Which type of radiation has the shortest wavelength?

Electromagnetic Radiation

- Light can be described in two ways:
 - *Behaves like waves*
 - *Behaves like particles*



Spectroscopy

- Is the study of the properties of light that depend on wavelength.
- *When the spectrum of a star is studied, the spectral lines act as “fingerprints.”*
- *These lines identify the elements present and thus the star’s chemical composition.*

Black Body and Line Spectra

Black Body

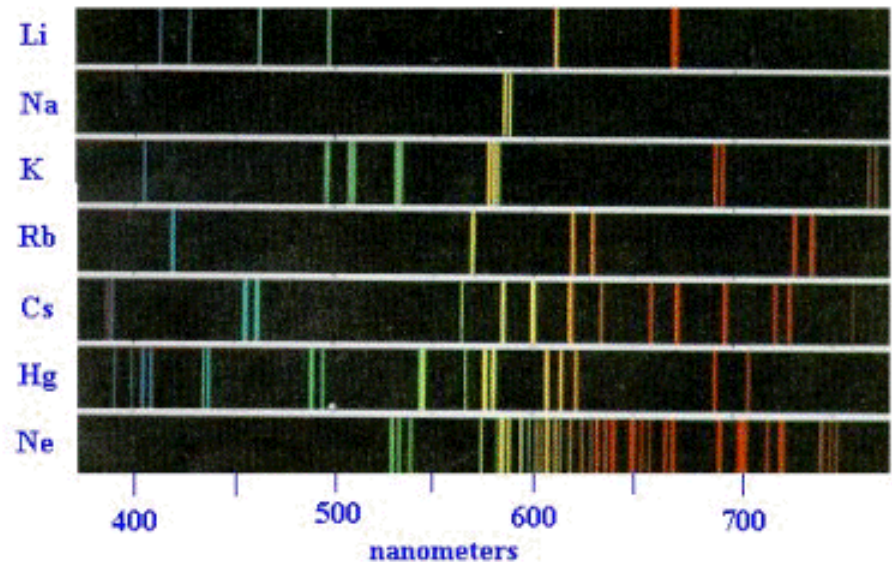

Spectroscopy

3 Types of Spectrums

- Continuous spectrum
 - uninterrupted band of light emitted by an incandescent solid, liquid, or gas
- Absorption spectrum
 - continuous spectrum produced when white light passes through a cool gas under low pressure.
 - The gas absorbs selected wavelengths of light, and the spectrum looks like it has dark lines
- Emission Spectrum
 - series of bright lines of particular wavelengths produced by a hot gas under low pressure.

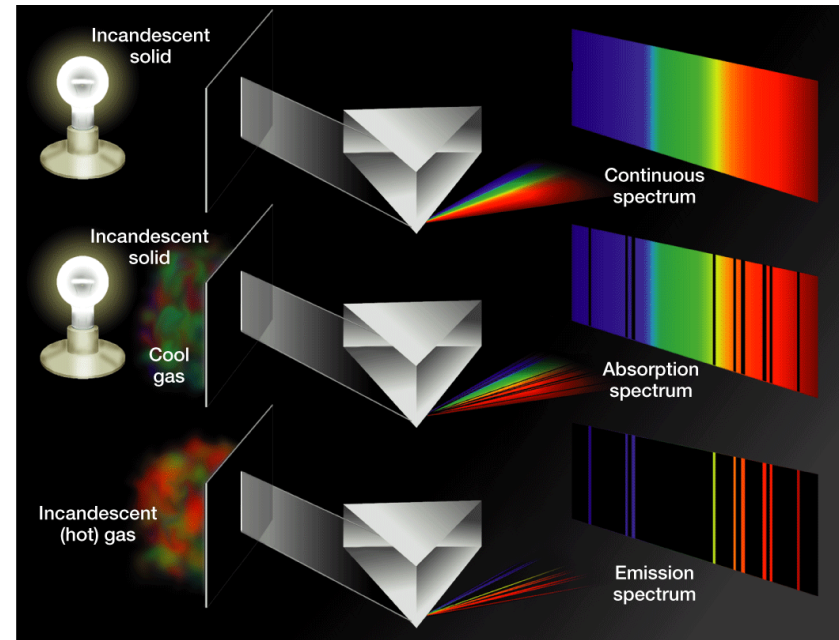

The Doppler Effect

- Refers to the perceived change in wavelength of a wave that is emitted from a source that is moving away or towards an object.
- *Used to determine if an object in space is moving away or toward Earth.*
 - *Toward = blue shift*
 - *Away = Red shift*
- *Larger Doppler shifts = higher speeds*

Figure 4 The Doppler Effect

The wavelength of the sound of an approaching ambulance is compressed as it approaches an observer. For a receding ambulance, the wavelength is stretched out and the observer notes a lower-pitched sound. When this effect is applied to light, a shorter wavelength is noted for an approaching object and is seen as blue light. A longer wavelength is noted for a receding object, which is seen as red light.

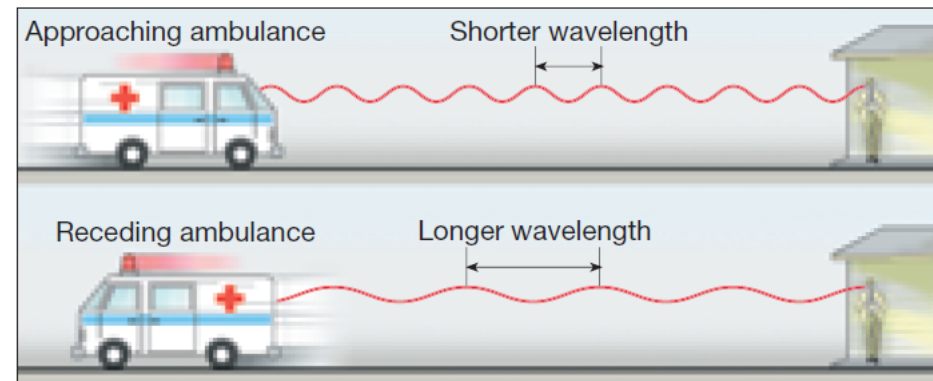

<http://science.discovery.com/videos/time-doppler-effect.html>

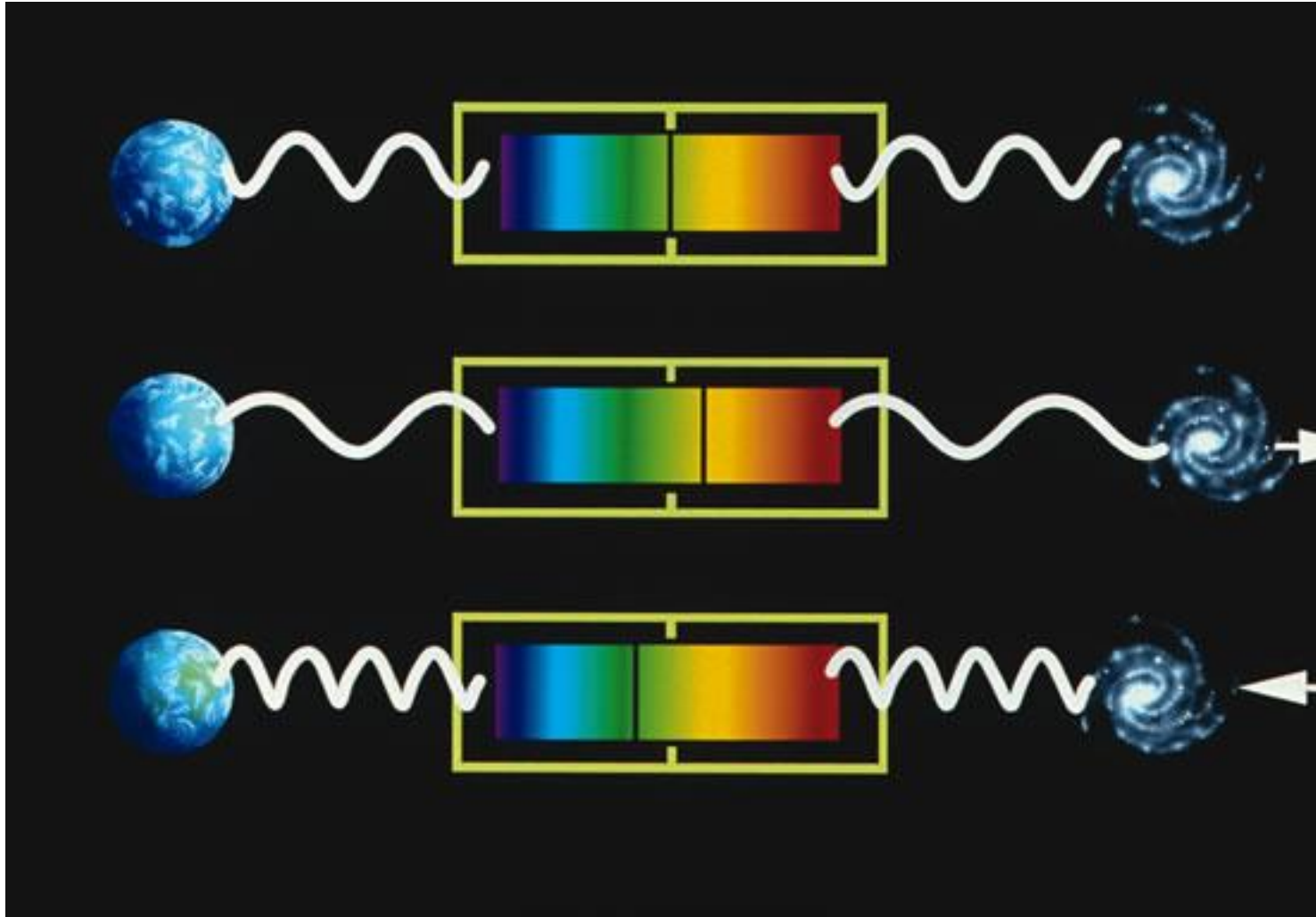

Chapter

24.2 Tools for Studying Space

You should be able to...

- ***Explain how refracting, reflecting, and radio telescopes work***
- ***Describe the advantages that space telescope has over an Earth-based telescope.***

24.2 Refracting Telescope

◆ A **refracting telescope** is a telescope that uses a lens to bend or refract light.

- The most important lens in a refracting telescope, the objective lens, produces an image by bending light from a distant object so that the light converges at an area called the focus (focus = central point).

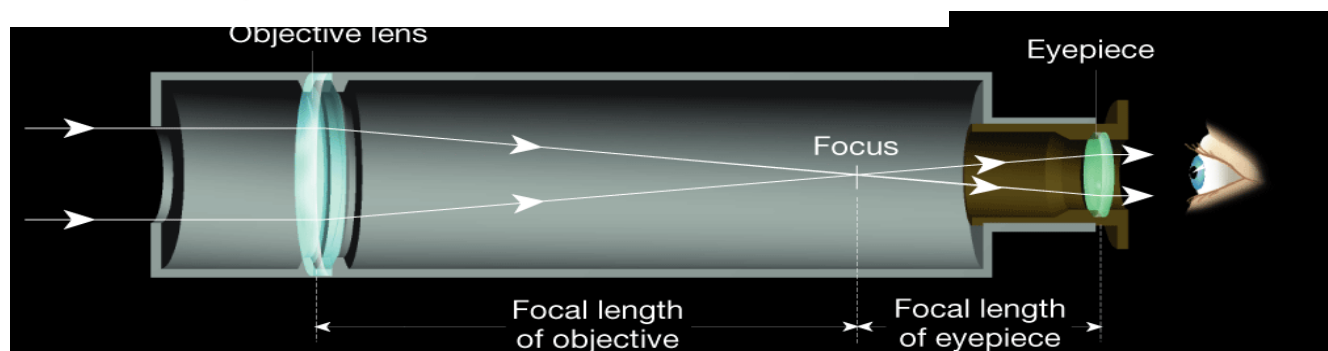
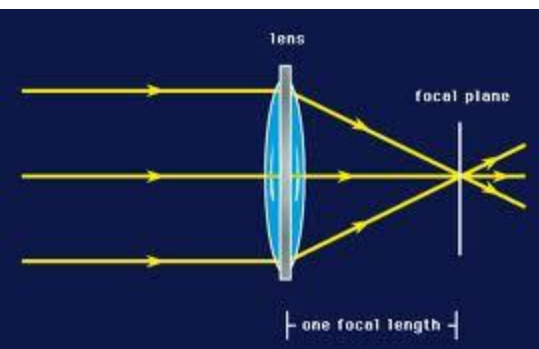
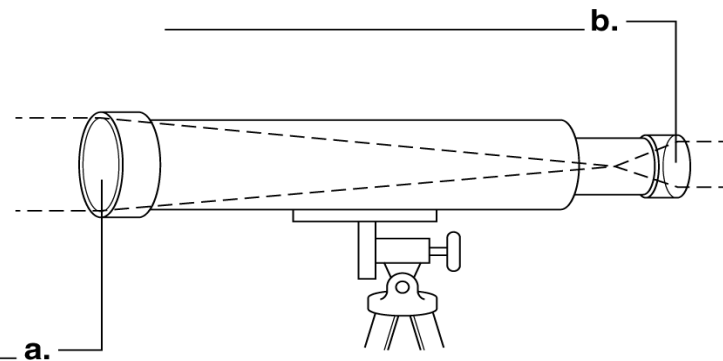

Reflecting Telescope

- ◆ A **reflecting telescope** is a telescope that reflects light off a concave mirror, focusing the image in front of the mirror.

- ◆ Advantages of Reflecting Telescopes

- Most large optical telescopes are reflectors. Light does not pass through a lens, so the glass for a reflecting telescope does not have to be of optical quality.

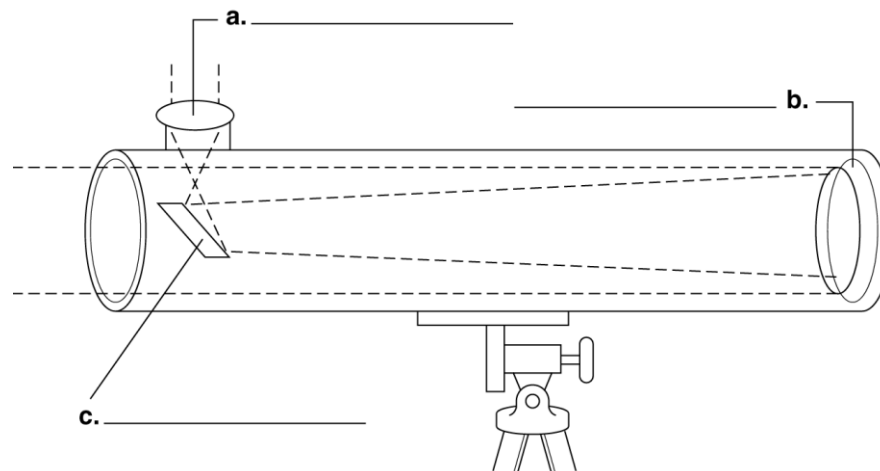
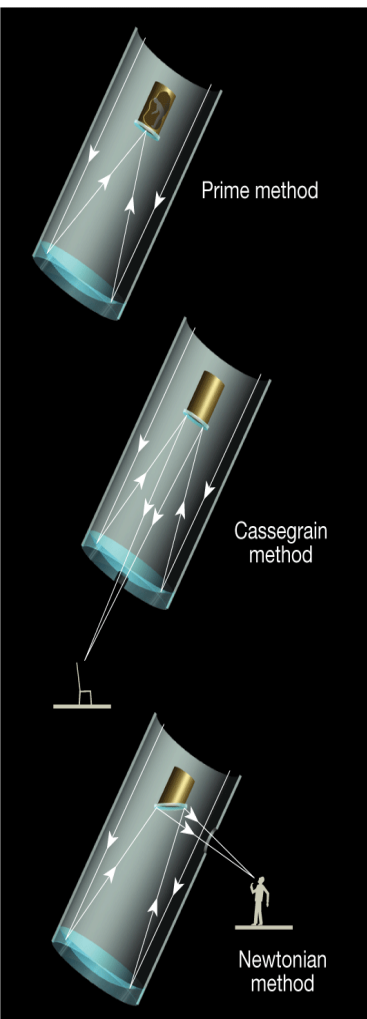

Properties of Optical Telescopes

- Both refracting and reflecting telescopes have three properties that aid astronomers in their work:
 - Light-gathering power
 - Resolving power
 - Magnifying power

Radio Telescopes

- A **radio telescope** is a telescope designed to make observations in radio wavelengths.
- Advantages of Radio Telescopes
 - Radio telescopes are much less affected by turbulence in the atmosphere, clouds, and the weather.
 - No protective dome is required.
 - Radio telescopes can “see” through interstellar dust clouds that obscure visible wavelengths.



Jupiter: radio
(21 cm)

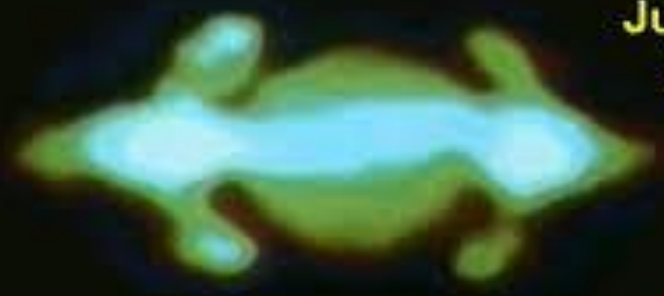

Jupiter: visible

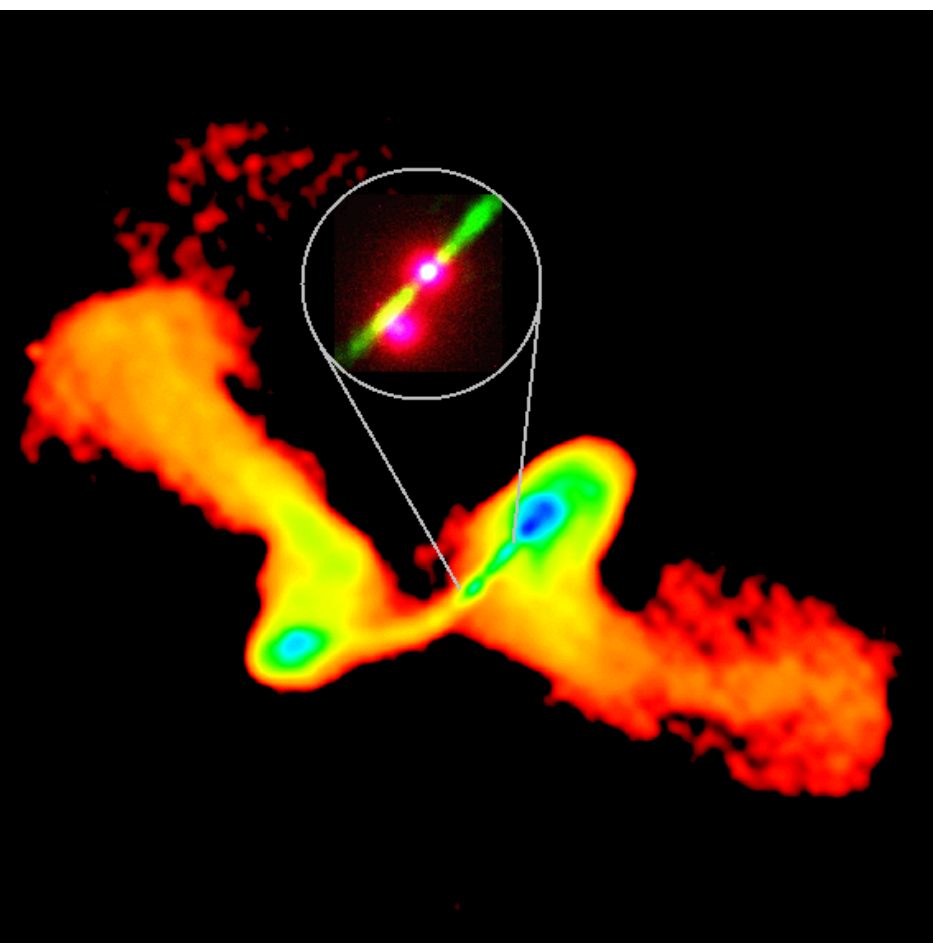
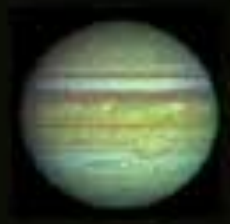

Space Telescopes

- ◆ Space telescopes orbit above Earth's atmosphere and thus produce clearer images than Earth-based telescopes.
- ◆ Hubble Space Telescope
 - The first space telescope, built by NASA, was the Hubble Space Telescope. Hubble was put into orbit around Earth in April 1990.

